

Step 01

Use the provided M2.5 Threading Tool to make thread on the 3.0mm ball caps.

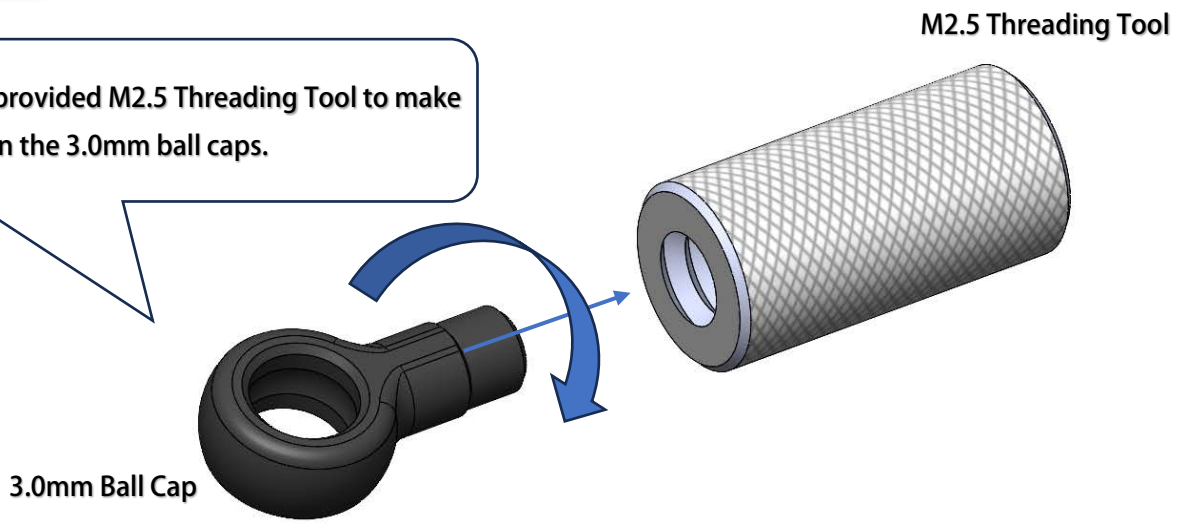

Make 4 pcs

Step 02

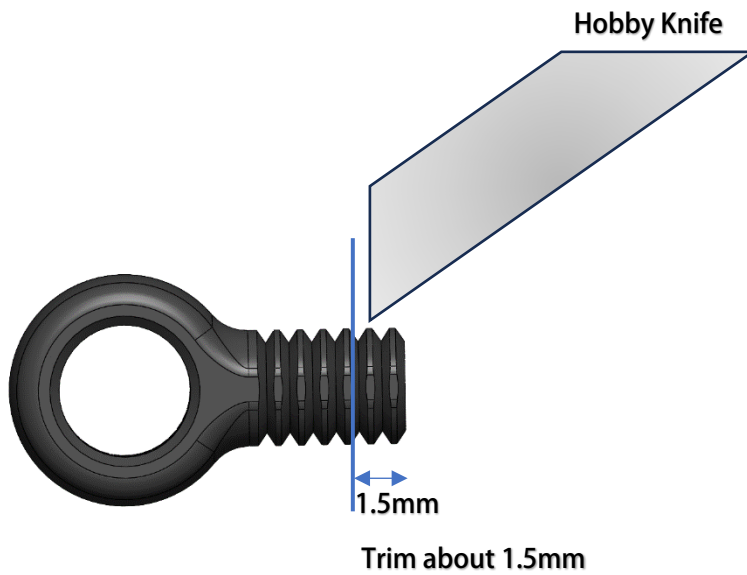

Make 4 pcs

Step 03

Screw in the ball cap to the damper tube.

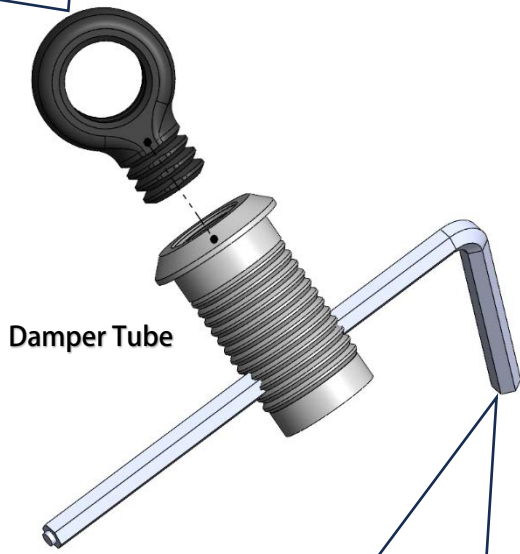

Use 0.9mm hex tool to hold the damper tube

Use 0.9mm hex tool to hold the damper tube

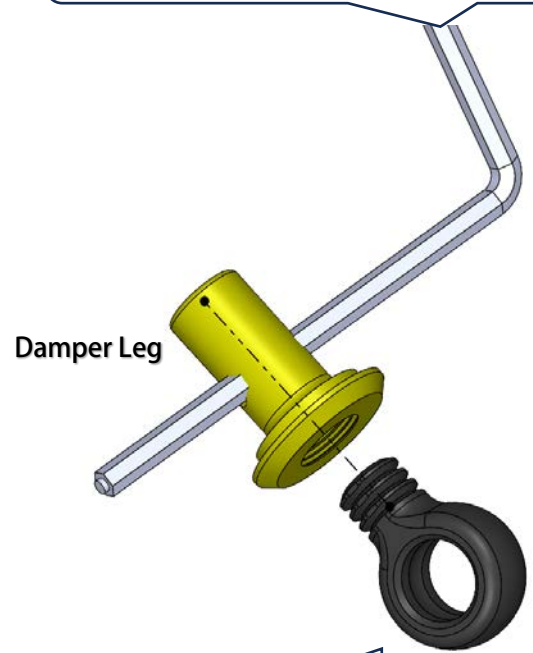

Screw in the ball cap to the damper Leg.

Step 04

Insert the O-Ring to the groove of the spring tension collar.

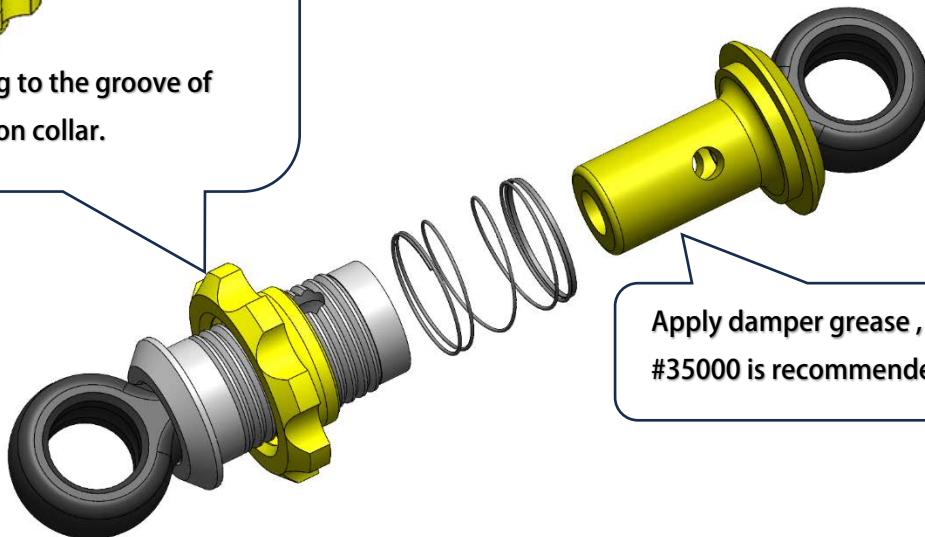
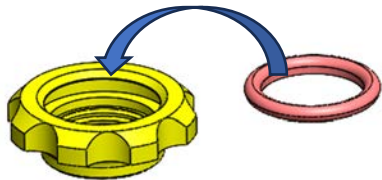

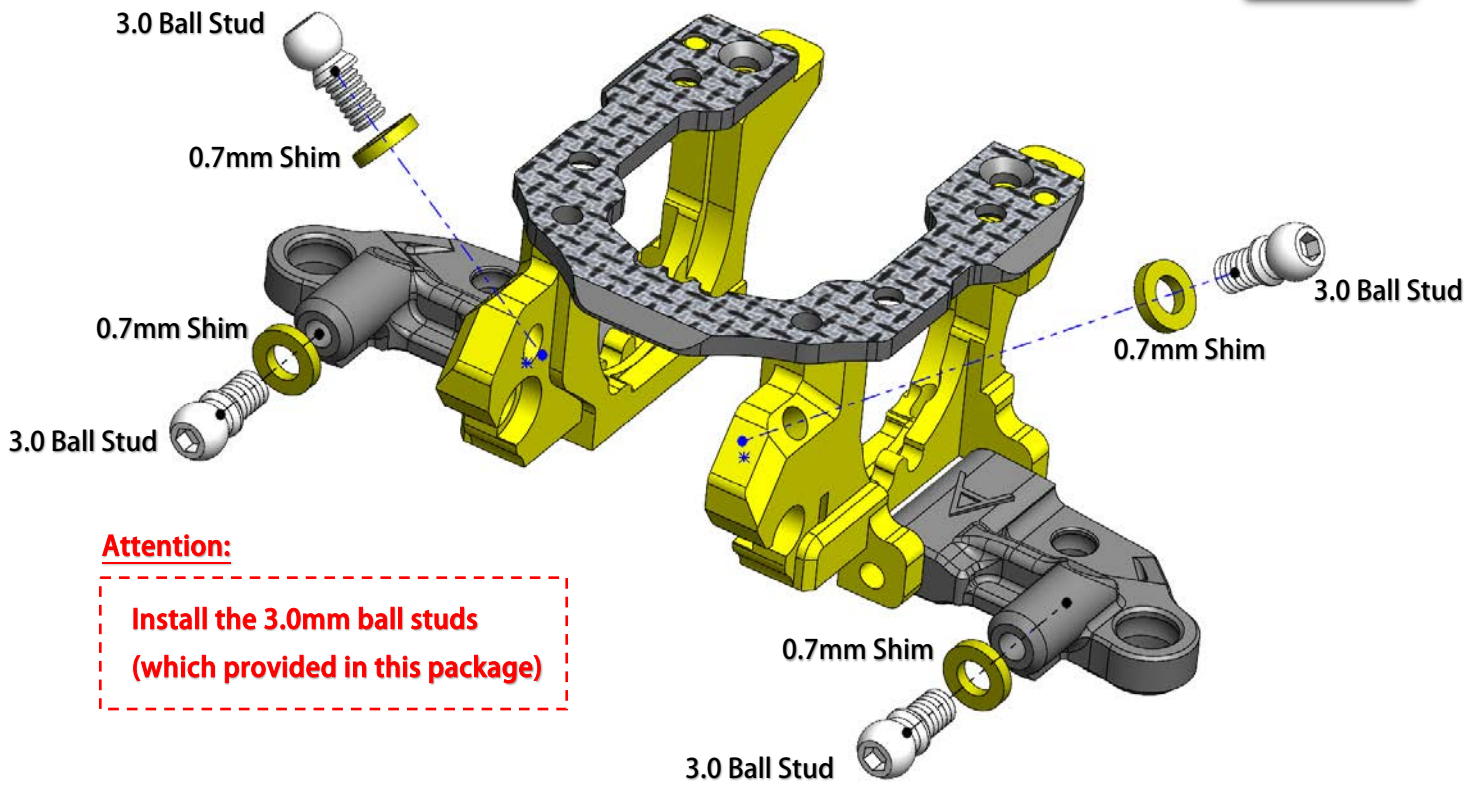

Last Step

Put on the dampers to the car

