

## MRZ V1.1 Setup Notes

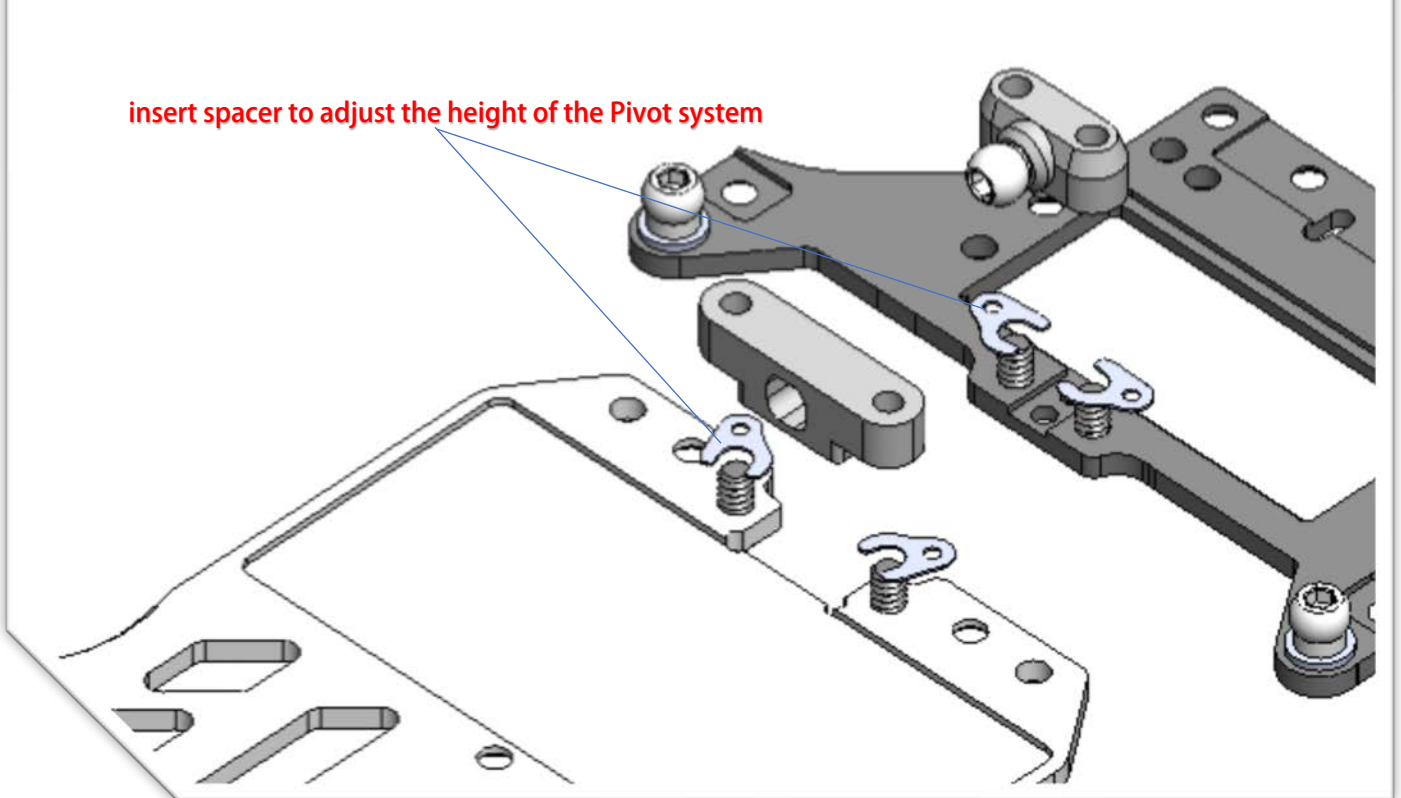

### Important:

Must use same amount of spacer in both Front and Rear Pivot Mount, that means if you raise 0.4mm in the rear you must also raise 0.4mm in the front.

### Effect:

- Raise the pivot system will also raise the "Roll Center" of the car, it will give you more steering and rear of the car rotate faster.
- Lower the Roll Center will increase the rear grip.
- 0.2mm will give you big effect, please adjust the height of the system according to your driving style.